

DAVEY

DAVEY CrystalClear®ER SERIES

Cartridge Filters

Models: DCC135, DCC180, DCC225, DCC270

Installation and Operating Instructions



This equipment must be installed and serviced by a qualified technician. Improper installation may result in property damage, serious injury or death. Improper installation and/or operation will void the warranty.



This manual contains important information about the installation, operation and safe use of this product.

Please pass these instructions on to the owner of this equipment once the product has been installed.

Contents:

DAVEY CRYSTAL CLEAR WATER CARTRIDGE FILTERS.....	3
INSTALLATION.....	3
START UP PROCEDURE.....	4
MAINTENANCE.....	4
CLEANING.....	5
TROUBLESHOOTING GUIDE.....	6

DAVEY CRYSTAL CLEAR WATER CARTRIDGE FILTERS

Davey Crystal Clear Cartridge Filters do not require a media such as sand or D.E powder to operate, instead the filter contains a cartridge element which is easily removed to clean or replace. All Davey Crystal Clear Filters are ideal for use in swimming pool and spas. The Davey Crystal Clear Cartridge Filters is also ideal for use when backwashing is impractical.

INSTALLATION

The filter should be placed in its permanent location, preferably as close to the pool as practicable. Position the filter tank and pump on a level concrete slab or similar base. Allow sufficient space around the filter for routine maintenance and provide for adequate ventilation and drainage.

Place the pump in position on the slab and locate the filter alongside with the appropriate pump inlet connection oriented towards the pump.

Davey Cartridge Filters are constructed of corrosion resistant materials. However, to ensure years of reliable performance, it is recommended that the filtration system is adequately protected from the weather.



CAUTION: Hand tighten the pressure gauge into the lid only for sealing.

Place the Davey Crystal Clear Cartridge Filter into the required position. Ensure that it is on a flat level surface and is aligned with the pump.

The Davey Crystal Clear Cartridge Filter has marked inlet and outlet ports.

Ensure that the pipe extending from the pump outlet is connected to the Davey Crystal Clear Cartridge Filter marked inlet.

Screw the supplied half barrel unions and tails onto the inlet and outlet before gluing the UPVC piping onto the filter.

Piping should be independently supported and not impose heavy loads on the filter or pump. Use 40mm or 50mm pipe for pump and pool return lines. 50mm should always be used if length of piping is over 15m.

If the pump and filter are located below pool water level, it is necessary to fit isolating valves in the pipe between the pump and the pool, and in the return line from the filter to the pool.



CAUTION: Use only the recommended glue for the connection pipes and fittings.

Cut and fit the pipe and fittings onto and the pump the Davey Crystal Clear Cartridge Filter. REFER to Pump Installation Manual for correct pump plumbing procedures.

It is best practice to fit all the cut pipe and fittings onto the filtration system before gluing; this will ensure that the system has been aligned correctly.

Glue the pipe and fittings onto the pump, filter and pool return lines and allow the glue to set for 24 hours before commissioning the system.

It is advisable to bolt the filter down to the floor where the filter is located. This will prevent the filtration plumbing from working with dyna bolts loose with the expansion and operation of the filter during regular cycles. It will also help to prevent unnecessary stress on the plumbing while unscrewing the filter lid lock ring.

START UP PROCEDURE

The Davey Crystal Clear Cartridge Filters are a simple and effective unit which will provide years of trouble free service if the following maintenance procedures are maintained.

To start up the filtration system either from new or after cleaning is exactly the same.

1. Ensure that all valves installed before or after the filter are open.
2. Ensure that the filter is plumbed correctly. Pipe from pump outlet must be attached to the filter inlet port.
3. Loosen the air bleed screw on top of the filter lid.
4. Prime the swimming pool pump.
(Refer to the pump installation and operation manual).
5. Turn on the swimming pool pump and allow the pump to run until all the air has been expelled from the filter vessel. Water will run from the air bleed screw.
6. Tighten the air bleed screw.
7. The filter is primed and ready for operation. In some cases this may be required to be done a few times before the unit will remain primed and be fully operational.
8. Note the operating pressure of the filter when first installed and primed, once the readings are 50+ kPa higher the filter will require cleaning
9. Davey cartridge filters have a maximum pressure of 350kPa



CAUTION: Do not stand over the lid whilst adjusting the air bleed to purge the system of air. Injury may occur if air bleed screw comes loose.

MAINTENANCE

To ensure that you get maximum life from your Davey Crystal Clear Cartridge Filters you will need to maintain the filter regularly.

When the filter is first started and has been purged of air, note the pressure on the pressure gauge. This is what is known as the filter operation pressure and it is important that you be aware of this figure.

All filtration systems will operate at different pressures depending on the pool hydraulics.

You will need to clean the filter cartridge (element) once the pressure gauge has reached 50 kPa above the operating pressure.

The Davey Crystal Clear Cartridge Filters have a maximum operating pressure of 350 kPa.

NOTE: Eg. Filter operates normally at 60 kPa needs to be cleaned at 110 kPa.

CLEANING



ATTENTION: Ensure to relieve pressure from system prior to any cleaning work to be conducted.

1. Release pressure release screw on top of filter housing.
2. Remove the cartridge element from the filter tank.
3. Using a garden type hose clean the surface of the pleated elements. Make sure to clean between the pleats.

NOTE: Using high pressure cleaners may damage the cartridge.

4. Place the cartridge back into the filter tank ensuring that it is seated correctly.
5. Ensure lid "O"-ring is correctly re-installed.
6. Place the lid onto the tank and screw the lock ring down.
7. Ensure to place the lid "O"-ring on the lid before you start up the filter.
8. Refer to the start up procedure to re-commence operation.



NOTE: Algae, calcium, clay, sun tan oil and body oils can form a coating on the element which may not be easily removed with normal hosing. These materials can be removed by soaking the element in a de-greaser and/or de-scaler. Your local Davey Dealer will be able to recommend suitable products.



ATTENTION: Failure to undertake regular maintenance may cause damage not covered by warranty.

It is suggested that you should periodically remove the cartridge filter element and soak it over night in a suitable cartridge cleaning compound. This will remove any debris not removed by hosing down of the element.

The cleaning time depends upon the swimming pool condition and use. Intervals between cleaning the element should not exceed a period of 12 months in any instance.



DANGER: Hazardous suction. Do not block water entry into filtration system with any part of your body as the pressure can trap hair or body parts, causing severe injury or death. Do not block suction. Turn off pump immediately if someone becomes trapped.

FLOW

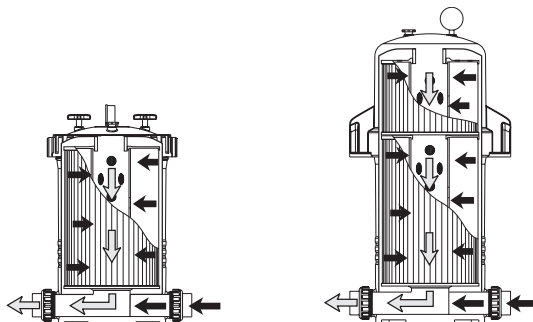

TROUBLE SHOOTING GUIDE

SYMPTOMS	POSSIBLE PROBLEMS / SOLUTIONS
Water is not clear	<p>Insufficient disinfectant level. Incorrect pool chemistry. Heavy bathing and/or dirt loads. Incorrect flow. Insufficient running times =. Increase pump run time. Filter is dirty. Clean per instructions. Hole in filter element.</p>
Low water flow	<p>Check strainer baskets for debris. Check for air leaks on suction side. Check for restrictions or blockage in either suction or return lines. Filter needs to be cleaned or replaced. Pool water level too low. Pump not primed. Pump impeller vanes blocked. Strainer baskets not being used and/ or not being cleaned regularly. Pump operating under speed (low voltage).</p>
Short filter cycles	<p>Presence of algae, check disinfectant content. Check pH and total alkalinity. Pump output exceeds design flow rate of filter, check pump performance. Ineffective cleaning, check conditions, replace filter cartridge.</p>
High pressure on start-up	<p>Small eyeball fitting in Pool/ Spa. Partially closed valve on return line. Too large of pump, check selection.</p>
Dirt returns to pool	<p>Hole in filter cartridge, replace filter cartridge. Worn "O"-ring seal inside filter, replace "O"-ring.</p>

Davey Warranty

Cartridge tank	10 years full warranty
All components	1 year, workmanship, materials, and labour

Please see below for conditions:

Davey Water Products Pty Ltd (Davey) warrants all products sold will be (under normal use and service) free of defects in material and workmanship for a minimum period of one (1) year from the date of original purchase by the customer as marked on the invoice, for specific warranty periods for all Davey products visit daveywater.com.

This warranty does not cover normal wear and tear or apply to a product that has:

- been subject to misuse, neglect, negligence, damage or accident
- been used, operated or maintained other than in accordance with Davey's instructions
- not been installed in accordance with the Installation Instructions or by suitably qualified personnel
- been modified or altered from original specifications or in any way not approved by Davey
- had repairs attempted or made by other than Davey or its authorised dealers
- been subject to abnormal conditions such as incorrect voltage supply, lightning or high voltage spikes, or damages from electrolytic action, cavitation, sand, corrosive, saline or abrasive liquids,

The Davey warranty does not cover replacement of any product consumables or defects in products and components that have been supplied to Davey by third parties (however Davey will provide reasonable assistance to obtain the benefit of any third-party warranty).

To make a warranty claim:

- If the product is suspected of being defective, stop using it and contact the original place of purchase. Alternatively, phone Davey Customer Service or send a letter to Davey as per the contact details below
- Provide evidence or proof of date of original purchase
- If requested, return the product and/or provide further information with respect to the claim. Returning the product to the place of purchase is at your cost and is your responsibility.
- The warranty claim will be assessed by Davey on the basis of their product knowledge and reasonable judgement and will be accepted if:
 - a relevant defect is found
 - the warranty claim is made during the relevant warranty period; and
 - none of the excluded conditions listed above apply
- The customer will be notified of the warranty decision in writing and if found to be invalid the customer must organise collection of the product at their expense or authorise its disposal.

If the claim is found to be valid Davey will, at its option, repair or replace the product free of charge.

The Davey warranty is in addition to rights provided by local consumer law. You are entitled to a replacement or refund for a major failure and compensation for any other reasonably foreseeable loss or damage. You are also entitled to have the goods repaired or replaced if the goods fail to be of acceptable quality and the failure does not amount to a major failure.

For any internet connected products the consumer is responsible for ensuring a stable internet connection. In the event of a network failure the consumer will need to address the concern with the service provider. Use of an App is not a substitute for the User's own vigilance in ensuring the product is working to expectation. Use of a Smart Product App is at the User's own risk. To the fullest extent permitted by law Davey disclaims any warranties regarding the accuracy, completeness or reliability of App data. Davey is not responsible for any direct or indirect loss, damage or costs to the User arising from its reliance on internet connectivity. The User indemnifies Davey against any claims or legal actions from them or others relying on internet connectivity or App data may bring in this regard.

Products presented for repair may be replaced by refurbished products of the same type rather than being repaired. Refurbished parts may be used to repair the products. The repair of your products may result in the loss of any user-generated data. Please ensure that you have made a copy of any data saved on your products.

To the fullest extent permitted by law or statute, Davey shall not be liable for any loss of profits or any consequential, indirect or special loss, damage or injury of any kind whatsoever arising directly or indirectly from Davey products. This limitation does not apply to any liability of Davey for failure to comply with a consumer guarantee applicable to your Davey product under local laws and does not affect any rights or remedies that may be available to you under local laws.

For a complete list of Davey Dealers visit our website (daveywater.com).

DAVEY

Davey Water Products Pty Ltd
A member of the Waterco Group
ABN 18 066 327 517

daveywater.com

AUSTRALIA

Head Office

6 Lakeview Drive,
Scoresby, Australia 3179
Ph: 1300 232 839
Fax: 1300 369 119
Email: sales@daveywater.com

NEW ZEALAND

7 Rockridge Avenue,
Penrose, Auckland 1061
Ph: 0800 654 333
Fax: 0800 654 334
Email: sales@dwp.co.nz

EUROPE

7 rue Eugène Hénaff 69200
Vénissieux, France
Ph: +33 (0) 4 72 13 95 07
Fax: +33 (0) 4 72 33 64 57
Email: info@daveyeurope.eu

NORTH AMERICA

Ph: 1-888-755-8654
Email: info@daveyusa.com

MIDDLE EAST

Ph: +971 50 6368764
Fax: +971 6 5730472
Email: info@daveyuae.com